

Features

- : 650 nm wavelength range
- : low current bias
- : Other configurations available on request

Description

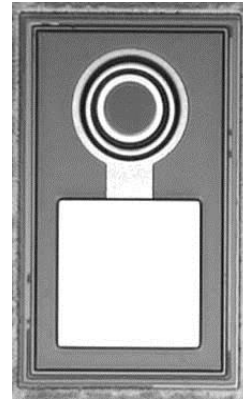

Applications

- : Industrial applications
- : Sensors

Absolute Maximum Ratings

Parameter	Rating
Storage Temperature	-40 to 100 °C
Operating Temperature	-20 to 70 °C
Continuous Forward Current	10mA
Continuous Reverse Voltage	5V (@10µA)

Dimensions

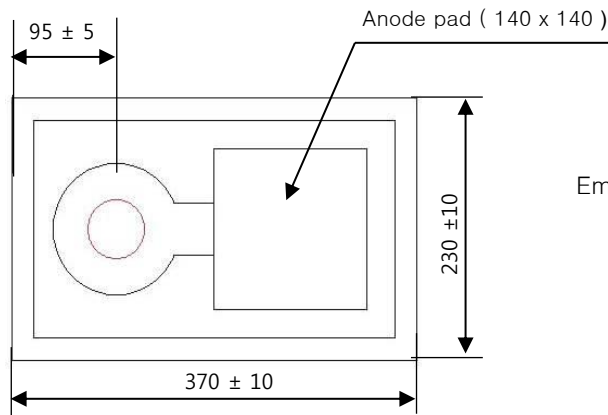

Emission area : Ø 50 µm

Unit : µm

Die Height : 200 ± 15 µm



Electro-Optics Characteristics (T<sub>a</sub>=25°C unless otherwise stated)

Parameters	Symbol	Specified			Unit	Test Conditions
		Min.	Typ.	Max.		
Total Radiant Flux	Φ <sub>o</sub>	0.2			mW	I <sub>f</sub> = 5mA
Peak Wavelength	λ <sub>p</sub>	640	650	665	nm	I <sub>f</sub> = 5mA
Forward Voltage	V <sub>f</sub>		2.1	2.25	V	I <sub>f</sub> = 5mA
Breakdown Voltage	V <sub>b</sub>		-10		V	

Test Data were measured in TO header of wire bonded chip

Value is referenced to the vender's measurement system (correlation to customer product is required).

Notes

\* These specifications are subject to change without notice.



NOTICE

The inherent design of this component causes it to be sensitive to electrostatic discharge(ESD). To prevent ESD-induced damage and/or degradation to equipment, take normal ESD precautions when handling this product